

V. BFMG30-20210420

BFMG30

OWNER'S MANUAL

WARNING, SAFETY, & MAINTENANCE

THERE IS A RISK ASSUMED BY INDIVIDUALS WHO USE THIS TYPE OF EQUIPMENT. TO MINIMIZE RISK, YOU MUST FOLLOW THESE RULES:

Inspect equipment before each workout. Check that all nuts, bolts, screws and pop pins are in place and fully tightened. Also, before use, check cables for sign of wear. Replace all worn parts immediately. Never use machine if any parts are damaged or missing.

FAILURE TO FOLLOW THESE RULES MAY RESULT IN SERIOUS INJURY.

Keep clear of the cables and all moving parts when machine is in use. Always make sure all Snap Links are closed when doing cable/pulley/strap exercises. Exercise with care. Perform your exercises at a smooth moderate pace; never perform jerky or uncoordinated movements that may cause injury.

It is recommended that you workout with a training partner.

Do not allow children or minors to play on or around this equipment.

If unsure of proper use of equipment, call your local Best Fitness distributor or the Best Fitness customer service center at 1-800-556-3113.

WARNING: Consult your physician before starting your exercise program. For your own safety, do not begin any exercise program without proper instruction.

MAINTENANCE SCHEDULE

Check the function and integrity of the following components. As noted, inspect equipment before each workout. Replace all damaged, broken or worn components immediately.

Cables:	Check tension, end fittings, and coating	✓
	Check that locking nut at weight stack is tight	✓
Upholstery:	Wipe down and dry	✓
	Clean and condition	✓
Frame:	Wipe down and dry	✓
	Polish / Wax	✓
Chrome:	Wipe down and dry	✓
	Polish / Lubricate	✓
Nut / Bolts / Fasteners: Tighten and / or adjust as needed		✓
Guide Rods: Lubricate and clean		✓
Linear Rods: Lubricate and clean		✓
Seat Sleeves: Lubricate and clean		✓
Adjustments / Locking Pins / Tightening Knobs		✓
Weight Stack Pins		✓
Warning Instruction Labels		✓
Springs / Pop Pins		✓
Anti Skid Surfaces		✓
Hand Grips / Rollers		✓

For Body-Solid Customer Service
Call 1-800-556-3113
#MSSTR0808

WARNING!

Safety and Maintenance of Cables

IMPORTANT: Cables are wear items. It is your responsibility to prevent unexpected breakage. **Cable inspection should be performed daily.**

Inspect all cables, the nylon coating on all cables, and the area near fitting at each end of each cable. **Replace and damaged or worn cable immediately.**

Do not allow the machine to be used until damaged or worn cables are replaced. Using or allowing a machine to be used with a suspect cable can result in serious injury. See Owner's Manual for more information.

For Body-Solid Customer Service
Call 1-800-556-3113

DO NOT REMOVE WARNING LABELS FROM MANUAL OR MACHINE

TABLE OF CONTENTS

- **SAFETY INSTRUCTIONS** **PAGE 4**
- **PREPARATION** **PAGE 5**
- **PART LIST**..... **PAGE 6**
- **HARDWARE ILLUSTRATION** **PAGE 11**
- **ASSEMBLY INSTRUCTIONS** **PAGE 18**
- **EXPLODED VIEW** **PAGE 38**
- **CONTACT PAGE** **PAGE 40**

IMPORTANT SAFETY INSTRUCTIONS

Before beginning any fitness program, you should obtain a complete physical examination from your physician.

Il est conseillé de subir un examen médical complet avant d'entreprendre tout programme d'exercice. Si vous avez des étourdissements ou des faiblesses, arrêtez les exercices immédiatement.

Antes de comenzar cualquier programa de ejercicios, deberías tener un examen físico con su doctor.

When using exercise equipment, you should always take basic precautions, including the following:

- Read all instruction before using the **BFMG30**. These instructions are written to ensure you safety and to protect the unit.
- **Do not remove any safety labels from the machine.**
- Do not allow children on or near the equipment.
- Use the equipment only for its intended purpose as described in this guide. Do not use accessory attachments that are not recommended by the manufacturer. Such attachments might cause injuries.
- Wear proper exercise clothing and shoes for you workout, no loose clothing.
- Keep hands, limbs, loose clothing, and long hair well out of the way of all moving parts.
- Use care when getting on or off the unit.
- Do not overexert yourself to work to exhaustion.
- If you feel any pain or abnormal symptoms, stop your workout immediately and consult your physician
- Never operate the unit when it has been dropped or damaged. Return the equipment to a service center for examination and repair.
- Never drop or insert objects into any opening in the equipment.
- Always check the unit before each use. Make sure that all fasteners are secure and in good working condition.
- Do not use the equipment outdoors or near water.

Personal Safety During Assembly

- Before beginning assembly, please take the time to read the instructions thoroughly.
- Read each step in the assembly instructions and follow the steps in sequence. Do not skip ahead. If you skip ahead, you may learn later that you have to disassemble components and that you may have damaged the equipment.
- Assemble and operate the **BFMG30** on a solid, level surface. Locate the unit a few feet from the walls or furniture to provide easy access.

The **BFMG30** is designed for your enjoyment. By following these precautions and using common sense, you will have many safe and pleasurable hours of healthful exercise with your Best Fitness **BFMG30 HOME GYM**.

After assembly, you should check all functions to ensure correct operation. If you experience problems, first recheck the assembly instructions to locate any possible errors made during assembly. If you are unable to correct the problem, call the dealer from whom you purchased the machine or call **1-800-556-3113** for the dealer nearest you.

Obtaining Service

Please use this Owner's Manual to make sure that all parts have been included in your shipment. When ordering parts, you must use the part number and description from this Owner's Manual. Use only Best Fitness replacement parts when servicing this machine. Failure to do so will void your warranty and could result in personal injury.

For information about product operation or service, go to www.bestfitness.com or contact an authorized Best Fitness dealer or a Best Fitness factory-authorized service company or contact Best Fitness customer service at one of the following:

Toll Free: 1-800-556-3113
Phone: 1-708-427-3555
Fax: 1-708-427-3556
Hours: M-F 8:30-5:00 CST
E-Mail: service@bodysolid.com

**Or write to: Best Fitness
Service Department
1900 S. Des Plaines Ave.
Forest Park, IL 60130 USA**

Retain this Owner's Manual for future reference. If you need to order replacement parts please be prepared to provide the following information when contacting us so that we can assist you better.

- 1. Model Number**
- 2. Place of Purchase**
- 3. Serial Number (S/N)**
- 4. Part # and Description**

PREPARATION

Thank you for purchasing the **BFMG30**. This machine is part of the Best Fitness line of quality strength training machines, which lets you target specific muscle groups to achieve better muscle tone and overall body conditioning. To maximize your use of the equipment please study this Owner's Manual thoroughly.

Required Tools

The basic tools that you must obtain before assembling the **BFMG30** include but are not limited to:

- Metric Allen Key Set
- Standard Allen Key Set
- Standard Wrench Set
- Metric Wrench Set
- Adjustable Wrench
- Screwdriver (standard and/or phillips)

Installation Requirements

Follow these installation requirements when assembling the **BFMG30**:

Set up the **BFMG30** on a solid, flat surface. A smooth, flat surface under the machine helps keep it level. A level machine has fewer malfunctions.

Provide ample space around the machine. Open space around the machine allows for easier access.

Insert all bolts in the same direction. For aesthetic purposes, insert all bolts in the same direction unless specified (in text or illustrations) to do otherwise.

Leave room for adjustments. Tighten fasteners such as bolts, nuts, and screws so the unit is stable, but leave room for adjustments. Do not fully tighten fasteners until instructed in the assembly steps to do so.

Fill out and mail the warranty card.

Assembly Tips

Read all "Notes" on each page before beginning each step.

While you may be able to assemble the **BFMG30** using the illustrations only, important safety notes and other tips are included in the text.

Some pieces may have extra holes that you will not use. Use only those holes indicated in the instructions and illustrations.

NOTE: With so many assembled parts, proper alignment and adjustment is critical. While tightening the nuts and bolts, be sure to leave room for adjustments.

NOTE: The bottles that are marked "Poison" is your touch up paint. Keep away from children.

CAUTION: Obtain assistance! If you feel like you can't assemble the **BFMG30** by yourself then do not attempt to do so as this could result in injury. Review the installation requirements before proceeding with the following steps.

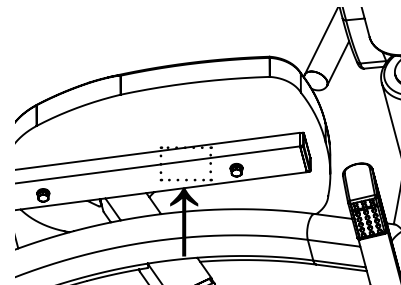

Your S/N# can
be found here

Best Fitness continually seeks ways to improve the performance, specifications and product manuals in order to ensure that only superior products are released from our factories. Please take the time to carefully read through this manual thoroughly. Instructions contained in this document are not intended to cover all details or variations possible with Best Fitness equipment, or to cover every contingency that may be met in conjunction with installation, operation, maintenance or troubleshooting of the equipment. Even though we have prepared this manual with extreme care, neither the publisher nor the author can accept responsibility for any errors in, or omission from, the information given. Should additional information be required, or should situations arise that are not covered by this manual, the matter should be directed to your local Best Fitness representative, or the Service Department at Body-Solid Inc. in Forest Park, Illinois.

Any Questions?
Call (800) 556-3113

BFMG30 - PART LIST

PART#	DESCRIPTION	QTY
A	LOWER MAIN FRAME	1
B	REAR LEG	1
C	REAR UPRIGHT	1
D	UPPER MAIN FRAME	1
E	REAR UPPER BEAM	1
G	GUIDE ROD	2
H	FLAT PLATE	1
J	FRONT FOOT PLATE	1
K	LEG EXTENSION ARM	1
L	SEAT PAD FRAME	1
M	BACK PAD FRAME	1
N	BACK PAD ADJUSTMENT	1
P	STABILIZING LEG	1
Q	PRESS ARM PIVOT	1
R	PRESS ARM	1
S	RIGHT HANDLE	1
T	LEFT HANDLE	1
V	UPPER FLOATING PULLEY BRACKET	1
W	LEG PRESS PULLEY BRACKET	1
X	LAB BAR	1
Y	LOW ROW BAR	1
Z	STEEL PLATE	1
AA	BACK/SEAT PAD	2

Part numbers are required when ordering parts.

BFMG30 - PART LIST

PART#	DESCRIPTION	QTY
1	END CAP 1 3/4" x 1 3/4"	2
2	END CAP 2" x 2"	2
3	METAL SPACER 1 1/8"L x 3/8" ID	4
4	PULLEY 4 1/4" OD	13
5	SHAFT 3/4" x 10" L	1
6	STEEL BUSHING 3/4" ID x 1 1/4" OD	2
7	END CAP 1" x 2"	2
8	SET SCREW M8x10mm	8
9	RUBBER GRIP 1 1/2" x 5 1/2"	4
10	RUBBER GRIP 1 1/4" x 5 1/2"	2
11	ROUND END CAP 1 1/2"	4
12	ROUND END CAP 1 1/4"	2
13	ROUND POP PIN	1
14	PULLEY SPACER 3/8" ID	16
15	PULLEY 3 1/2" OD	4
16	SHAFT 5/8" OD x 8" L	1
17	END CAP 3" x 1 1/2"	7
18	RUBBER COVER	2
19	RUBBER STOP 1 1/16" O.D. x 1 1/2" L	2
20	PLASTIC BUSHING 2"x2"	4
21	T-SHAPED POP PIN	2
22	FOAM ROLLER	6
23	END CAP 1"x 2"	4
24	PLASTIC ROLLER END CAP	6

Part numbers are required when ordering parts.

BFMG30 - PART LIST

PART#	DESCRIPTION	QTY
25	PLASTIC WASHER 3" OD	6
26	LONG T-SHAPED POP PIN 6"	1
27	SNAP LINK	5
29	RUBBER DONUT	2
30	PIN	1
31	SELECTOR ROD	1
32	SHAFT COLLAR	2
33	CABLE END SHAFT	1
34	SELECTOR ROD TOP BOLT	1
36	WEIGHT STACK PLATE	9
37	TOP PLATE	1
38	BUTTON HEAD CAP SCREW M8 x 20mm	2
39	FOAM ROLLER BAR 1"x18"	3
40	ACORN CAP NUT 3/16" PRE-INSTALLED	1
41	RUBBER APD 1" x 1"	2
42	RUBBER GRIP 1 1/2" x 20"	1
43	LAT BAR PAD	1
44	RUBBER GRIP 1 1/2" x 6"	2
45	SHAFT 1/2" x 3"	1
46	FOOT CAP 1 1/2" x 3"	4
47	JAM NUT 10mm	2
48	BRONZE BUSHING 5/16"ID	2
49	LONG CHAIN	1
50	HEX HEAD BOLT M10mm x 215mm	2
51	BUTTON HEAD CAP SCREW M10mm x 215mm	2

Part numbers are required when ordering parts.

BFMG30 - PART LIST

PART#	DESCRIPTION	QTY
52	HEX HEAD BOLT M10mm x 95mm	10
53	HEX HEAD BOLT M10mm x 45mm	5
54	HEX HEAD BOLT M10mm x 55mm	1
55	HEX HEAD BOLT M10mm x 65mm	8
56	HEX HEAD BOLT M8mm x 45mm	4
57	SOCKET HEAD CAP SCREW M6mm x 10mm	2
58	HEX HEAD BOLT M10mm x 105mm	2
59	HEX HEAD BOLT M10mm x 20mm	1
60	WASHER M10	28
61	WASHER M8	4
62	LOCK WASHER M8	4
63	LOCK WASHER M12	1
64	LOCK WASHER M10	1
70	NYLON LOCK NUT M10	32
71	JAM NUT M12	1
80	END CAP 1 1/4" x 2 3/4"	1
81	LEG EXTENSION BUSHING	2
82	RETAINING RING	2
83	AB STRAP	1
84	BRONZE BUSHING	2
90	HIGH PULLEY CABLE	1
91	LOW PULLEY CABLE	1
92	SHORT CABLE	1
93	PLASTIC BUSHING	1

Part numbers are required when ordering parts.

BFMG30 - PART LIST

PART#	DESCRIPTION	QTY
94	SPACER	2
95	HEX HEAD BOLT M12 x 135mm	1
96	NYLON LOCK NUT M12	1
97	WASHER M12	1
98	HEX HEAD BOLT M10 x 110mm	2
99	BUTTON HEAD CAP SCREW M10 x 20mm	2
100	BRONZE BUSHING	2
101	WASHER M10 x 30mm	4
102	LOCK WASHER M6	2
103	SET SCREW M6 x 8mm	1
104	LARGE WASHER M12	1
105	STEEL CHAIN	1

Part numbers are required when ordering parts.

HARDWARE ILLUSTRATION

Part #50

HEX HEAD BOLT M10x215mm

QTY. 2

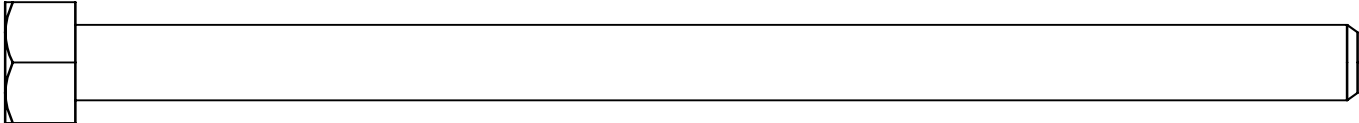

Part #51

HEX HEAD BOLT M10x60mm

QTY. 2

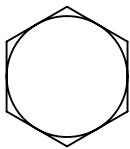
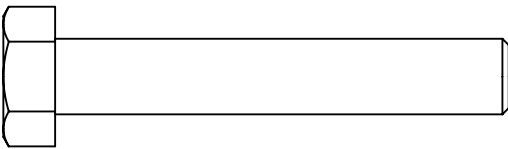

Part #52

HEX HEAD BOLT M10x95mm

QTY. 10

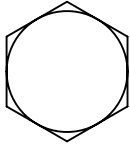
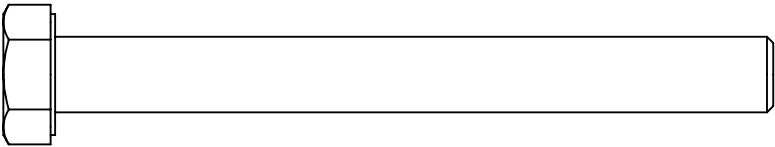

Part #53

HEX HEAD BOLT M10x45mm

QTY. 5

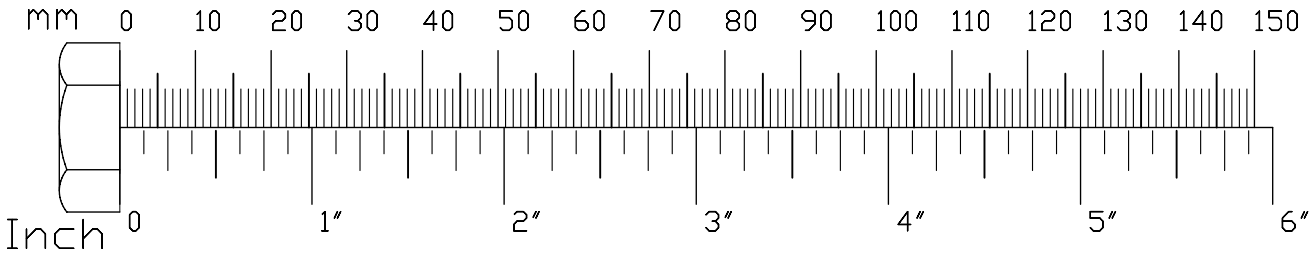
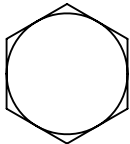
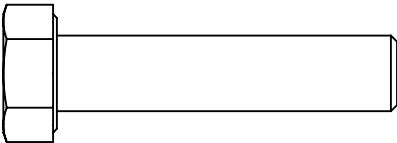

HARDWARE ILLUSTRATION

Part #54 HEX HEAD BOLT M10x55mm

QTY. 1

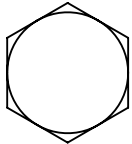
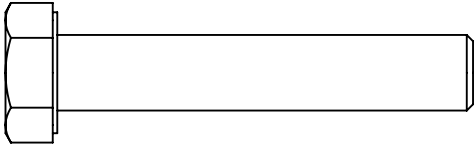

Part #55 HEX HEAD BOLT M10x65mm

QTY. 8

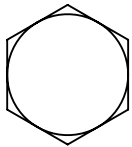
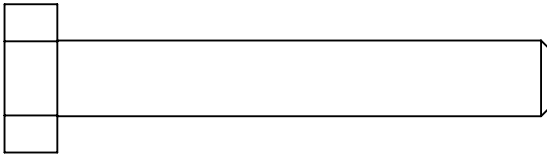

Part #56 HEX HEAD BOLT M8x45mm

QTY. 4

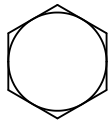
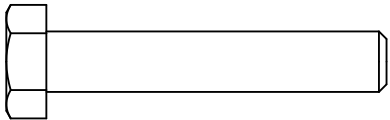

Part #57 SOCKET HEAD CAP SCREW M6x10mm

QTY. 2

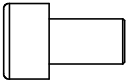

Part #58 HEX HEAD BOLT M10x105mm

QTY. 2

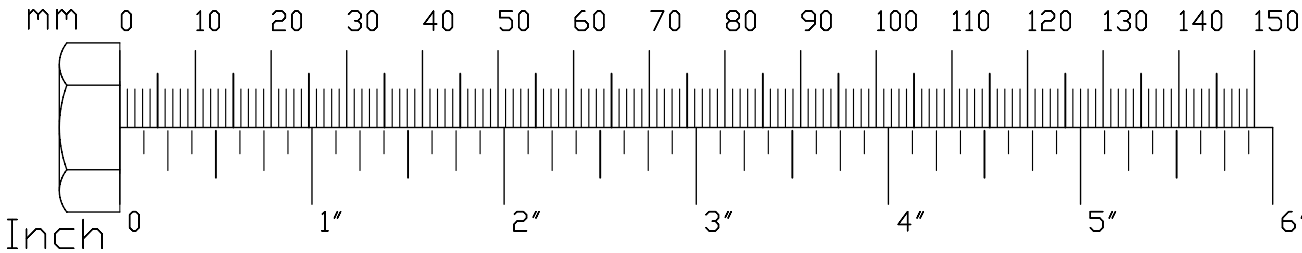
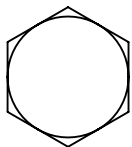
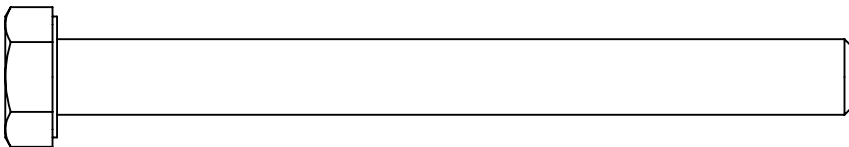

HARDWARE ILLUSTRATION

Part #59

HEX HEAD BOLT M10x20mm

QTY. 2

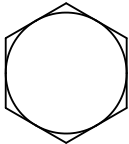
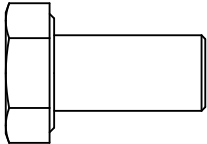

Part #60

WASHER M10

QTY. 28

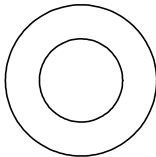

Part #61

WASHER M8

QTY. 4

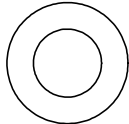

Part #62

LOCK WASHER M8

QTY. 4

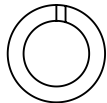

Part #63

LOCK WASHER M12

QTY. 1

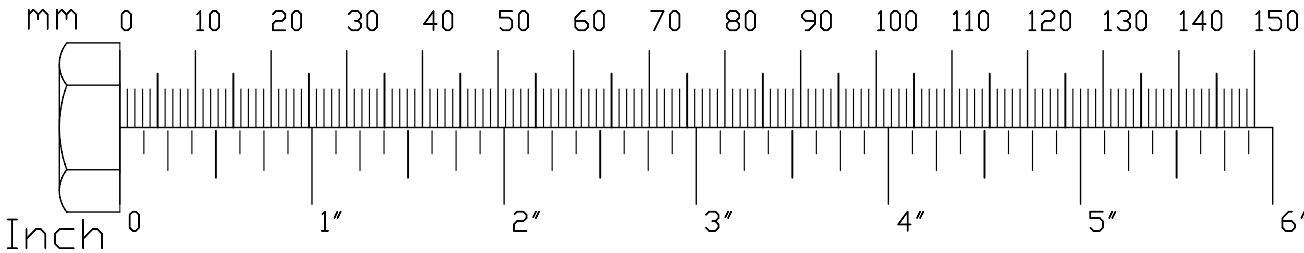
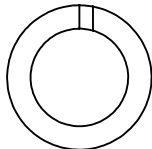

HARDWARE ILLUSTRATION

Part #64

LOCK WASHER M10

QTY. 1

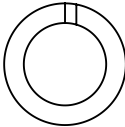

Part #70

NYLON LOCK NUT M10

QTY. 32

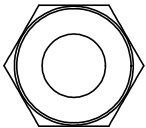
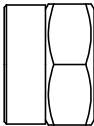

Part #71

JAM NUT M12

QTY. 1

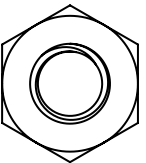

Part #95

HEX HEAD BOLT M12x135mm

QTY. 1

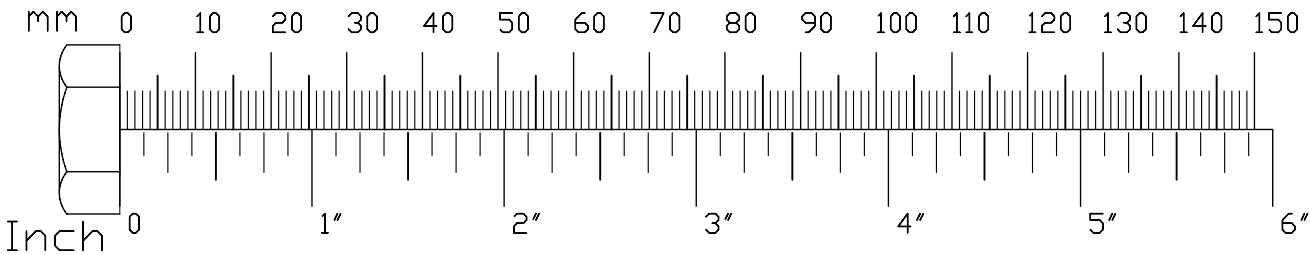
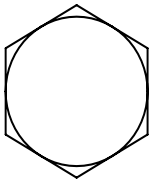
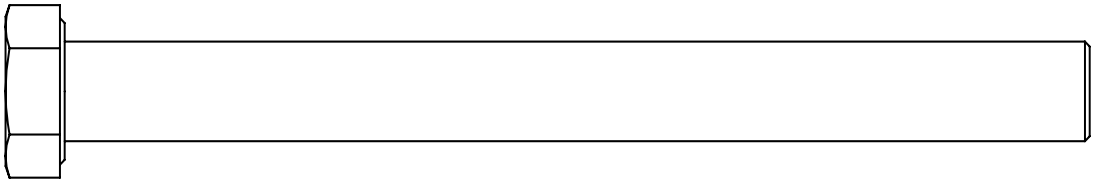

HARDWARE ILLUSTRATION

Part #96

NYLON LOCK NUT M12

QTY. 1

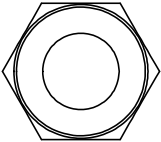
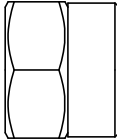

Part #97

WASHER M12

QTY. 1

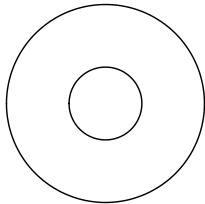

Part #98

HEX HEAD BOLT M10x110mm

QTY. 2

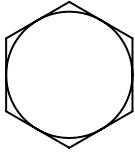
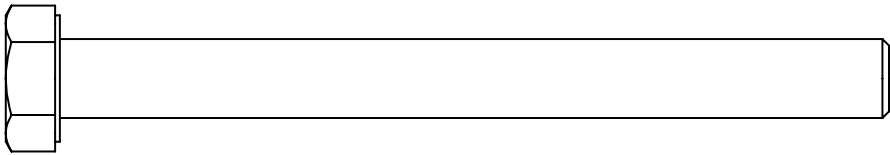

Part #99

BUTTON HEAD CAP SCREW M10x20mm

QTY. 2

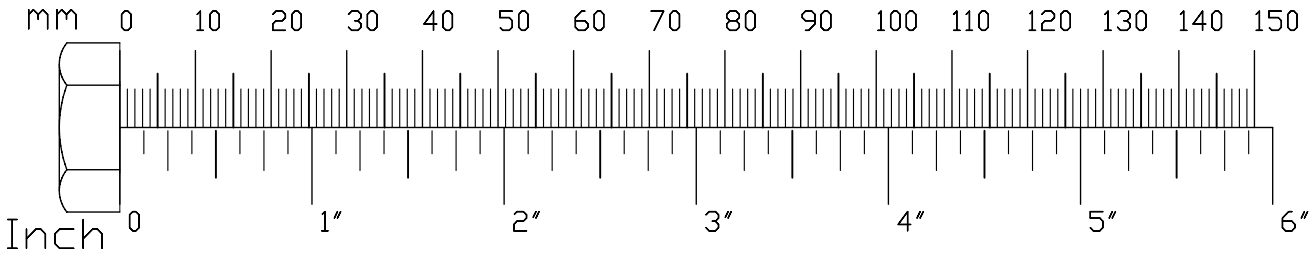
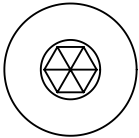
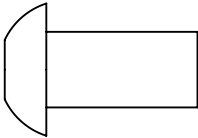

HARDWARE ILLUSTRATION

Part #101

WASHER M10x30mm

QTY. 4

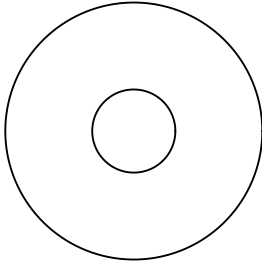

Part #102

LOCK WASHER M6

QTY. 2



Part #103

SET SCREW M6x8mm

QTY. 1



Part #104

LARGE WASHER M12

QTY. 1

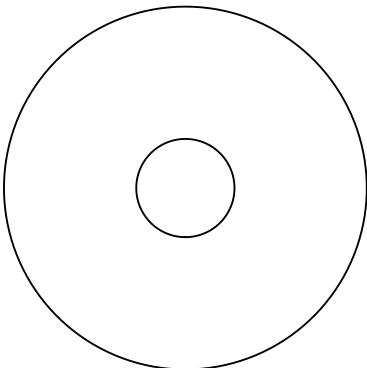

mm 0 10 20 30 40 50 60 70 80 90 100 110 120 130 140 150



Inch 0 1" 2" 3" 4" 5" 6"

NOTE

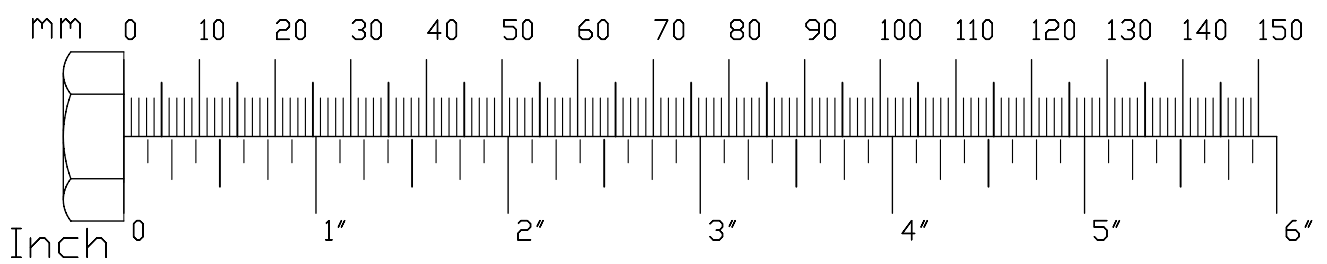

STEP**1**

Be careful to assemble all components in the sequence they are presented.

NOTE:

Finger tighten all hardware first. Wrench tighten at the end of Step 1D. Some components may be pre-assembled. Nylon lock nuts will not fully screw onto bolts, they must be wrench tighten to fully go on.

1A. Attach Stabilizing Leg (P) to Lower Main Frame (A) using:

- 1 - (#98) M10x110mm Hex Head Bolt
- 2 - (#101) M10 X 30mm Washer
- 2 - (#94) Spacer
- 1 - (#70) Nylon Lock Nut

Note: In Step 9, a pulley will be installed in this assembly. Please Finger tighten the nylon nut for easier removal.

1B. Attach Lower Main Frame (A) to Rear Upright (C) & Rear Leg (B) using:

- 2 - (#55) M10x65mm Hex Head Bolt
- 2 - (#70) Nylon Lock Nut

1C. Attach Upper Main Frame (D) to Lower Main Frame (A) using:

- 2 - (#58) M10x65mm Hex Head Bolt
- 2 - (#55) M10x65mm Hex Head Bolt
- 8 - (#60) M10 Washer
- 4 - (#70) Nylon Lock Nut
- 1 - (H) Steel Plate

1D. Attach Upper Main Frame (D) to Rear Upright (C) using:

- 2 - (#55) M10x65mm Hex Head Bolt
- 2 - (#70) Nylon Lock Nut
- 1 - (Z) Steel Plate

**1E. Attach one End Cap (#17) to Upper Main Frame (D).
Attach two Foot Caps (#46) to Stabilizing Leg (P).
Attach two Foot Caps (#46) to Rear Leg (B).**

Note: Parts (#17, #46) might be pre-installed.

STEP

1

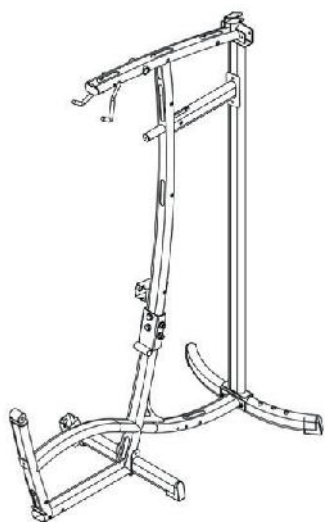

Above shows STEP 1 assembled and completed.

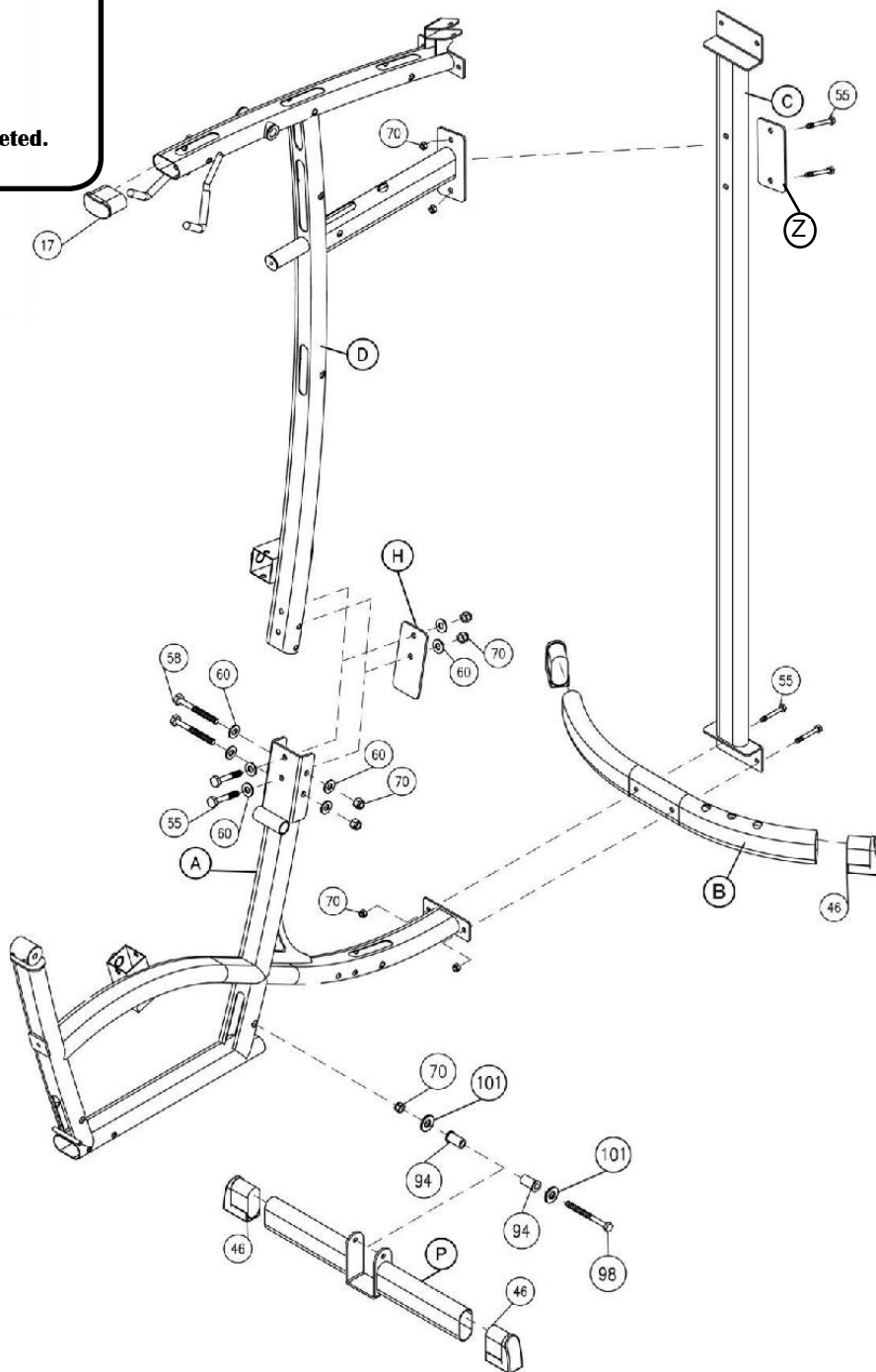

STEP**2**

Be careful to assemble all components in the sequence they are presented.

NOTE:

Finger tighten all hardware first. Some components may be pre-assembled.

- 2A. Place two Rubber Donuts onto Rear Leg (B) as shown. Slide two Guide Rods (G) through the Rubber Donuts (#29) and into the Rear Leg (B).**
- 2B. Slide Weight Plates (#36) onto Guide Rods (G).**
- 2C. Attach Selector Rod (#31) to Top Weight Plate (#37) using a Pin (#30) & Push Nut (#64).**
- 2D. Install M12 Large Washer (#104), M12 Lock Washer (#63), M12 Jam Nut (#71) & Top Bolt (#34) onto Selector Rod (#31).**
- 2E. Slide two Shaft Collar (#32) onto the two Guide Rods (G).**
- 2F. Insert Guide Rods (G) into Rear Upper Beam (E) and connect Rear Upper Beam (E) to Upper Main Frame (D) & Rear Upright (C) together using:**
 - 2 - (#55) M12x65mm Hex Head Bolt**
 - 2 - (#70) M12 Nylon Lock Nut**
- 2G. Slide Shaft Collars (#32) up and lock them by tightening the two M8x10mm Set Screws.**
- 2H. Attach End Caps (#17) to Rear Upper Beam (E).**

STEP

2

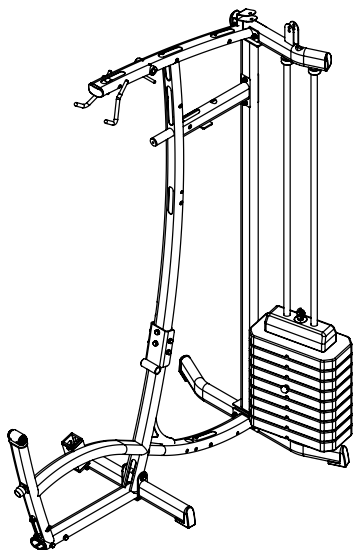

Above shows STEP 2 assembled and completed.

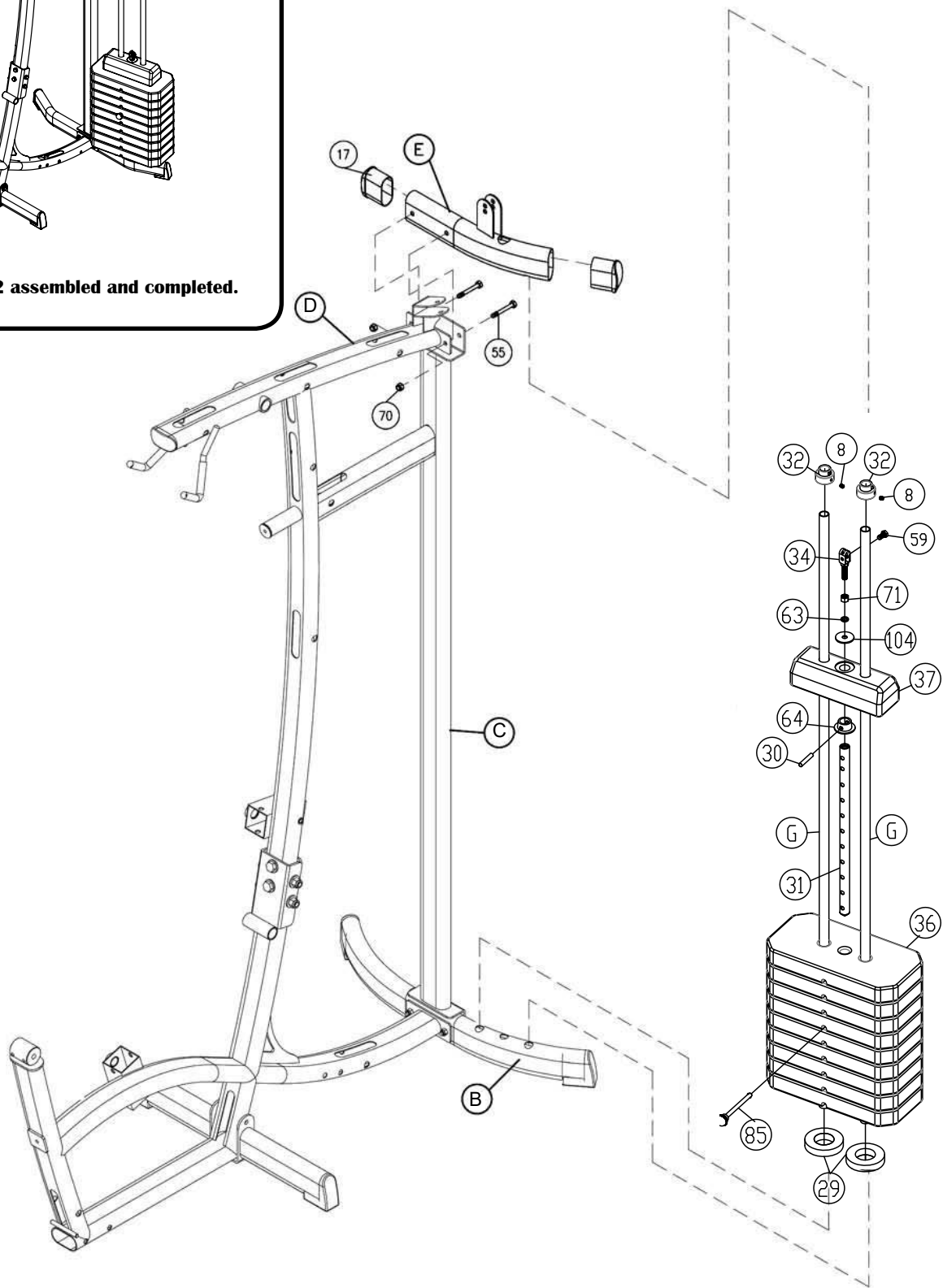

STEP**3**

Be careful to assemble all components in the sequence they are presented.

NOTE:

Finger tighten all hardware first. Some components may be pre-assembled.

- 3A. Insert Plastic Bushing (#93) into the lower Main Frame (A).**

- 3B. Attach Front Foot Plate (J) to Lower Main Frame (A) using:**
 - 2 - (#52) M10x95mm Hex Head Bolt**
 - 4 - (#60) M10 Washer**
 - 2 - (#70) M10 Nylon Lock Nut**

- 3C. Attach End Cap (#80) to Front Foot Plate (J).**

- 3D. Attach Leg Extension Arm (K) to Lower Main Frame (A) using:**
 - 2 - (#38) M8x20mm Button Head Cap Screw**
 - 4 - (#61) M8 Washer**
 - 1 - (#45) Shaft**
 - 2 - (#8) M8 x 10mm Set Screw**

- 3E. Attach Two End Cap (#17) to Leg Extension Arm (K).**

- 3F. Attach End Cap (#17) to Lower Main Frame (A).**

- 3G. Install Rubber Stop (#19) & M10 Jam Nut (47) into lower Main Frame (A)**

NOTE: Parts (#17, #80) might be pre-installed.

STEP

3

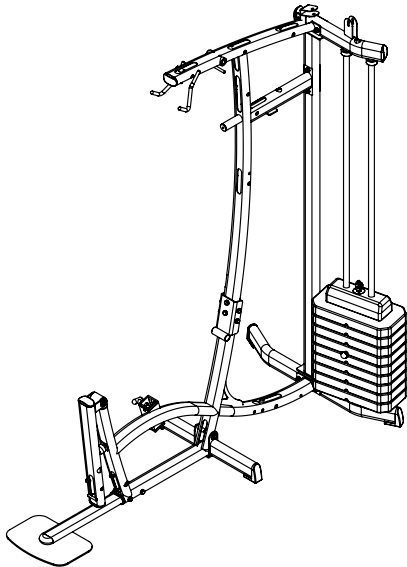

Above shows STEP 3 assembled and completed.

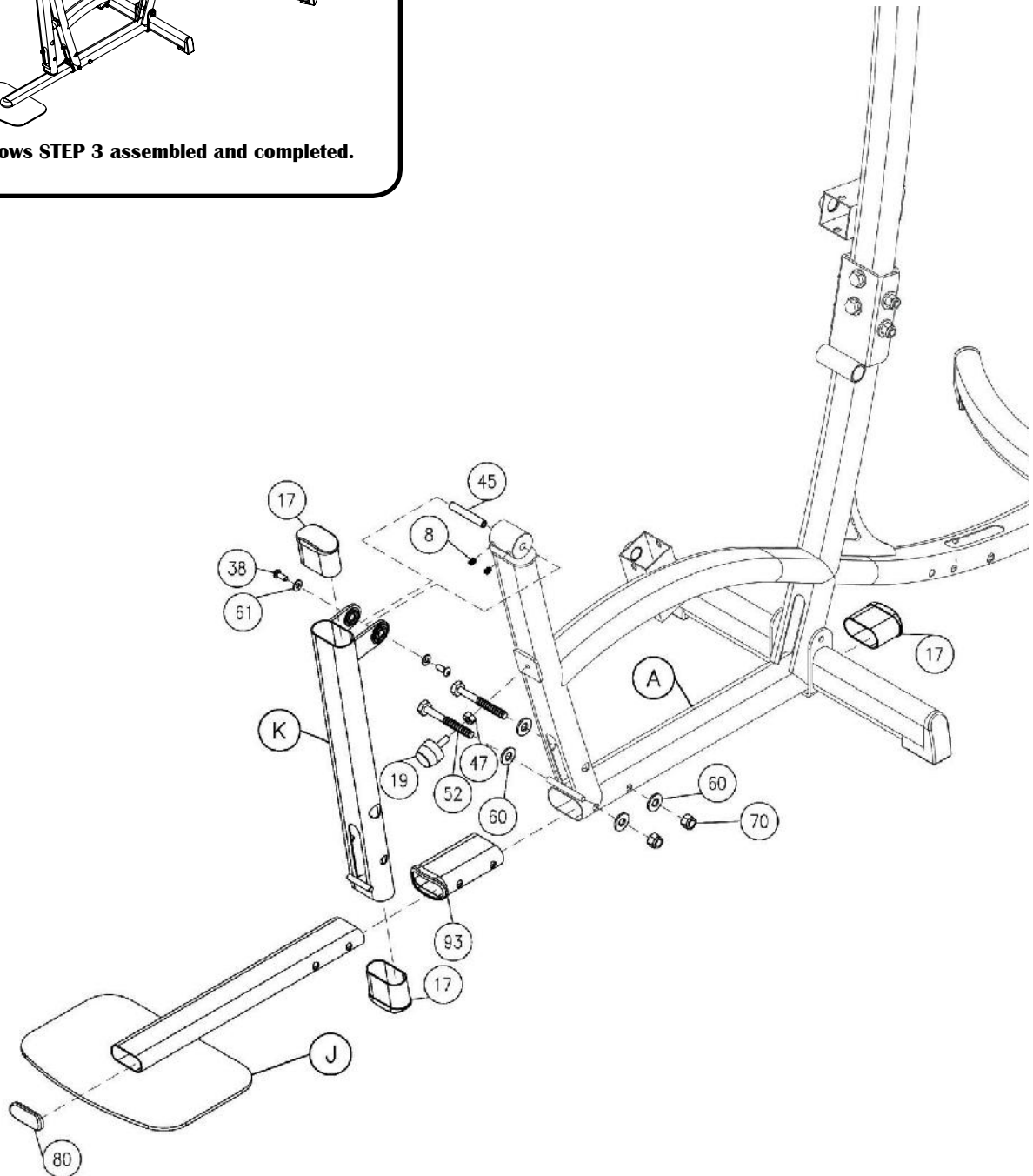

STEP**4**

Be careful to assemble all components in the sequence they are presented.

NOTE:

Finger tighten all hardware first. Wrench tighten at the end of Step 4K. Some components may be pre-assembled. Nylon lock nuts will not fully screw onto bolts, they must be wrench tighten to fully go on.

- 4A. Attach Seat Pad (AA) to the Seat Pad Frame (L) using:
2 - (#56) M8x45mm Hex Head Bolt
2 - (#62) M8 Lock Washer
2 - (#61) M8 Washer**
- 4B. Install two Plastic Bushings (#20) into Lower Main Frame (A). Slide the Seat Pad Frame (#20) into Lower Main Frame (A)**
- 4C. Screw M6x10mm Socket Head Cap Screw (#57) with M6 Lock Washer (#102) in the Seat Pad Frame (L).**
- 4D. Attach Back Pad (AA) to the Back Pad Frame (M) using:
2 - (#56) M8x45mm Hex Head Bolt
2 - (#62) M8 Lock Washer
2 - (#61) M8 Washer**
- 4E. Attach Back Pad Frame (M) to Back Pad Adjustment (N) using:
1 - (#95) M12x135mm Hex Head Bolt
1 - (#97) M12 Washer
1 - (#96) M12 Nylon Lock Nut
2 - (#84) Bronze Bushing**
- 4F. Install two Plastic Bushings (#20) into Upper Main Frame (D). Slide the Back Pad Adjustment (N) into Upper Main Frame (A).**
- 4G. Screw M6x10mm Socket Head Cap Screw (#57) with M6 Lock Washer (#102) into the Back Pad Adjustment (N).**
- 4H. Install Long T-Shaped Pop Pin into the Back Pad Adjustment (N).**
- 4J. Install T-Shaped Pop Pins (#21) into the Lower & Upper Main Frames (A & D)**
- 4K. Attach End Caps (#2 & 23) to the Seat Pad Frame (L), Back Pad Adjustment (N) and Back Pad Frame (M).**

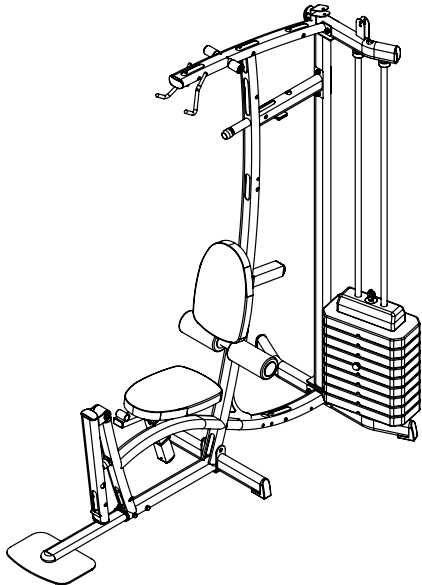

Above shows STEP 4 assembled and completed.

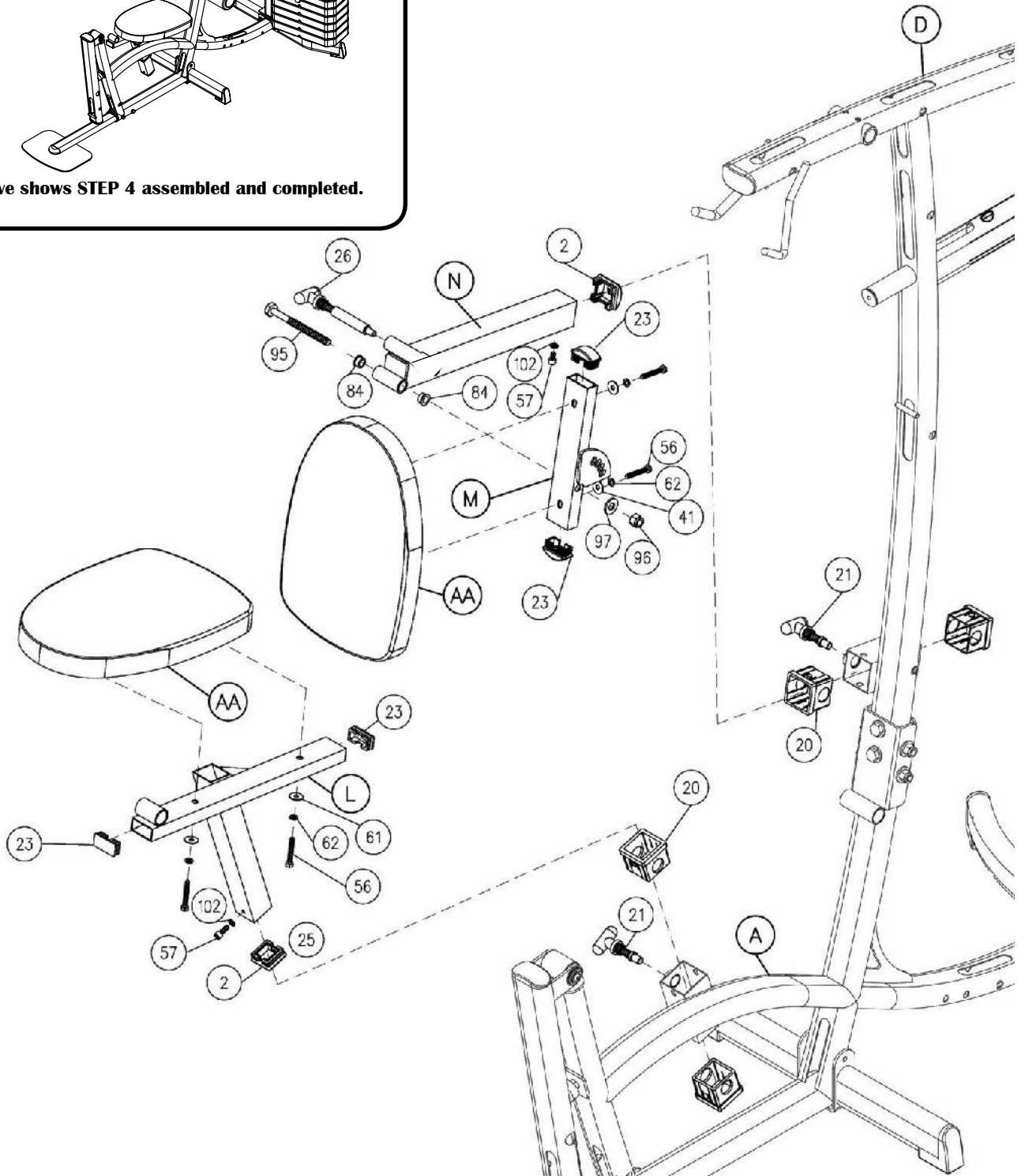

STEP**5**

Be careful to assemble all components in the sequence they are presented.

NOTE:

Finger tighten all hardware first. Wrench tighten at the end of Step 5F. Some components may be pre-assembled. Nylon lock nuts will not fully screw onto bolts, they must be wrench tighten to fully go on.

5A. Attach Press Arm Pivot (Q) to Upper Main Frame (D) using:

2 - (#99) M10x20mm Button Head Cap Screw

2 - (#101) M10x30mm Washer

2 - (#8) M8x10mm Set Screw

1 - (#16) Shaft

5B. Attach Press Arm (R) to Press Arm Pivot (Q) using:

2 - (#8) M8x10mm Set Screw

1 - (#5) Shaft

6 - (#6) Bushing

5C. Install Pop Pin (#13) into Press Arm.**5D. Install Rubber Stop (#19) and Jam Nut (#47) into Upper Main Frame (D).**

NOTE: Parts (#19, #47) might be pre-installed.

5E. Attach Handles (S & T) to Press Arm (R) using:

2 - (#51) M10x20mm Button Head Cap Screw

4 - (#60) M10 Washer

2 - (#70) M10 Nylon Lock Nut

5F. Attach two End Caps (#1) to the Press Arm Pivot (Q).

STEP

5

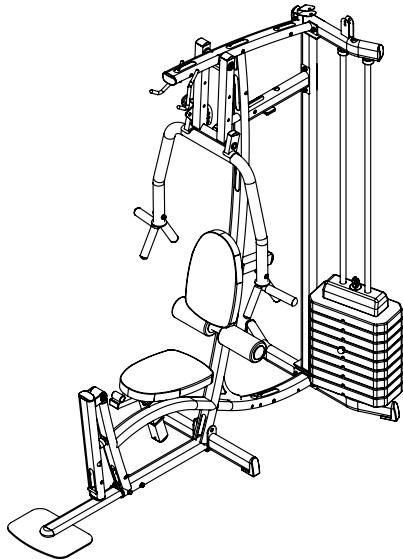

Above shows STEP 5 assembled and completed.

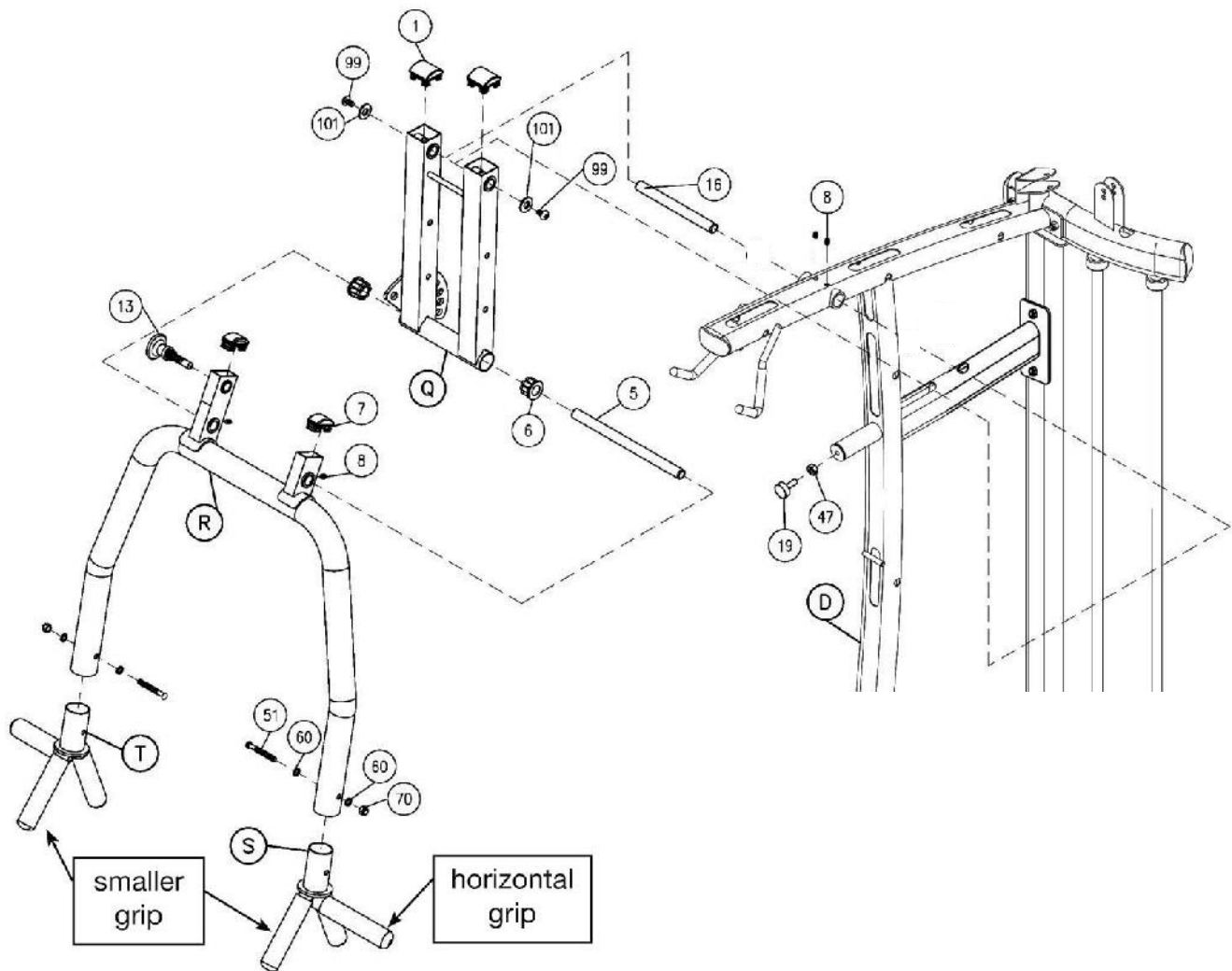

STEP**6**

Be careful to assemble all components in the sequence they are presented.

NOTE:

Finger tighten all hardware first. Wrench tighten at the end of Step 6C. Some components may be pre-assembled. Nylon lock nuts will not fully screw onto bolts, they must be wrench tighten to fully go on.

- 6A. Slide Foam Roller Bars (#39) into the Lower Main Fram (A), Seat Pad Frame (L) & Leg Extension Arm (K)**

- 6B. Install Plastic Washers (#25), Foam Rollers (#22) and Plastic Roller End Caps onto Lower Main Fram (A), SeatPad Frame (L) & Leg Extension Arm (K)**

- 6C. Install two 4 1/4" Pulley (#4) into Press Arm Pivot (Q) using:**
 - 2 - (#50) M10x225mm Hex Head Bolt**
 - 4 - (#60) M10 Washer**
 - 2 - (#70) M10 Nylon Lock Nut**
 - 4 - (#3) Pulley Spacer**

STEP**7**

Be careful to assemble all components in the sequence they are presented.

NOTE:

Finger tighten all hardware first. Wrench tighten at the end of Step 7A. Some components may be pre-assembled. Nylon lock nuts will not fully screw onto bolts, they must be wrench tighten to fully go on.

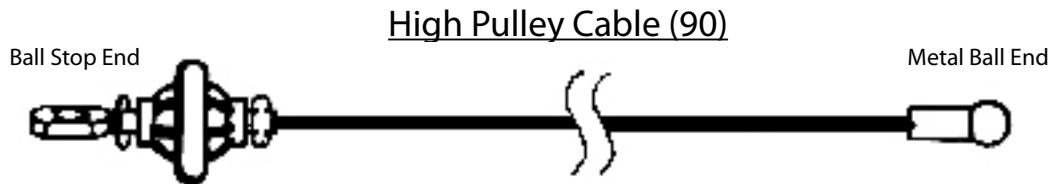

7A. Route Cable (#90) and install 4 Pulleys (#15 & #4) as shown in Step 7 Drawing using:

- 3 - (#52) M10x95mm Hex Head Bolt**
- 1 - (#54) M10x55mm Hex Head Bolt**
- 4 - (#70) M10 Nylon Lock Nut**
- 8 - (#14) Pulley Spacer**

Diagram 1
(cable installation)

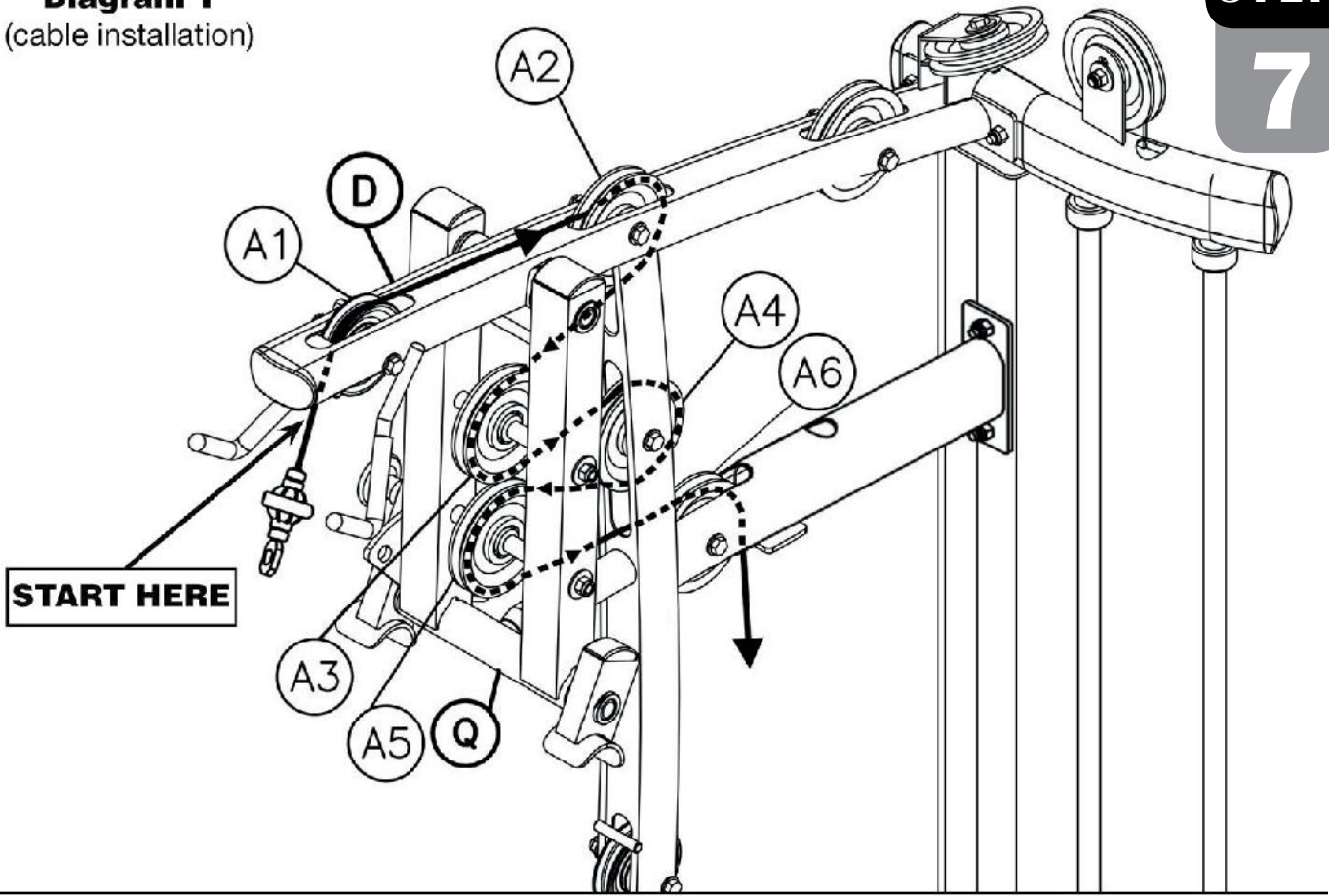
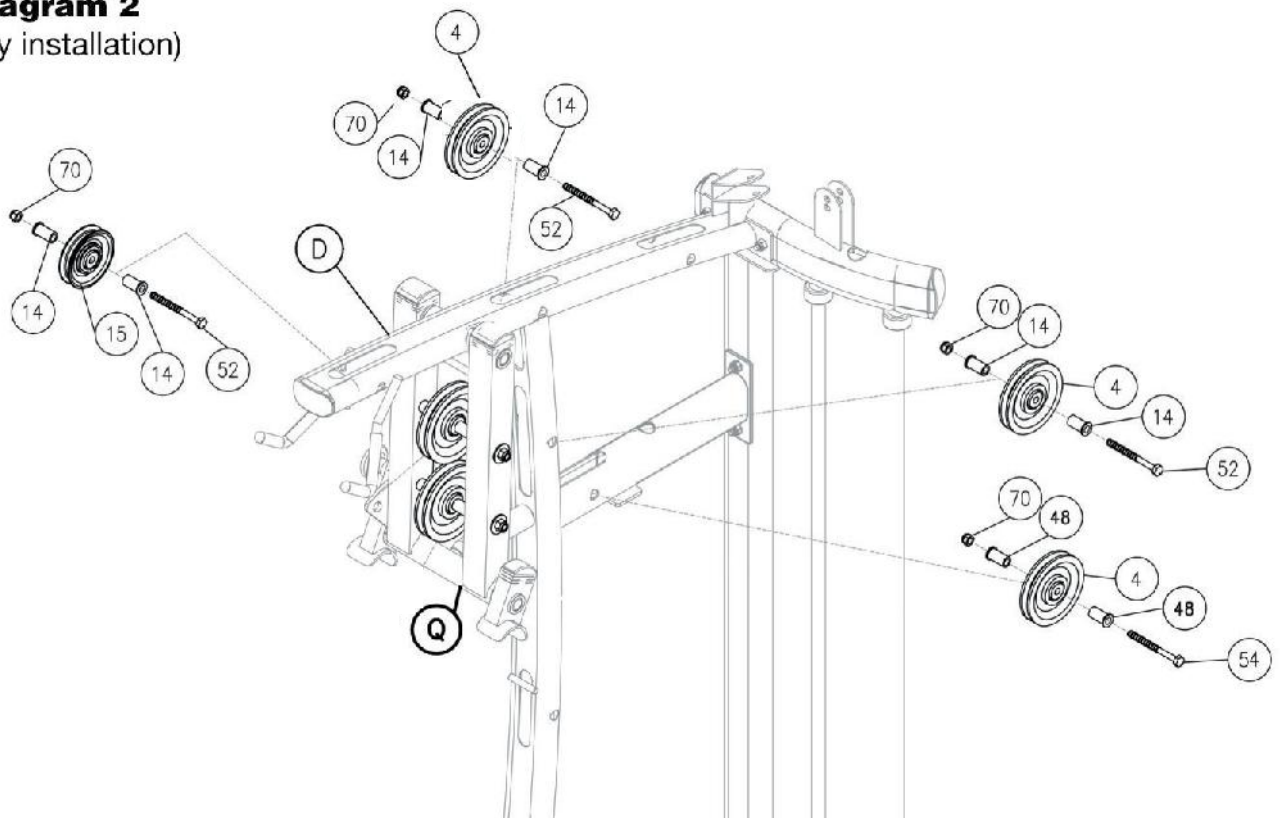

Diagram 2
(pulley installation)



STEP**8**

Be careful to assemble all components in the sequence they are presented.

NOTE:

Finger tighten all hardware first. Wrench tighten at the end of Step 8B. Some components may be pre-assembled. Nylon lock nuts will not fully screw onto bolts, they must be wrench tighten to fully go on.

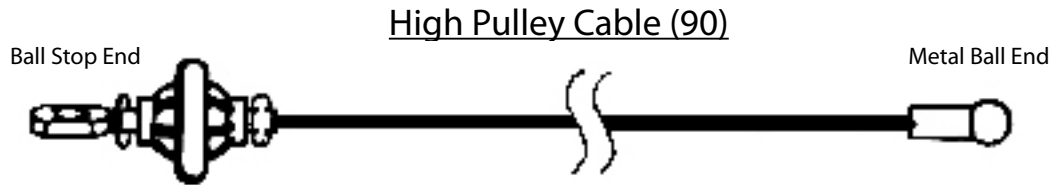

SA. Route Cable (#90) and install 4 Pulleys (#15 & 4) as shown in Step 8 Drawing using:

- 1 - (#52) M10x95mm Hex Head Bolt**
- 2 - (#53) M10x45MM Hex Head Bolt**
- 1 - (#54) M10x55mm Hex Head Bolt**
- 6 - (#60) M10 Washer**
- 4 - (#70) M10 Nylon Lock Nut**
- 2 - (#14) Pulley Spacer**
- 1 - (V) Upper Floating Pulley Bracket**

NOTE: Pulley Bracket (V) does not bolt to the Frame. It is suspended by the Cable (#90)

SB. Attach Cable (#90) to Selector Rod Top Bolt (#34) and follow the installation instruction in the Diagram 1A.

Diagram 1
(cable installation)

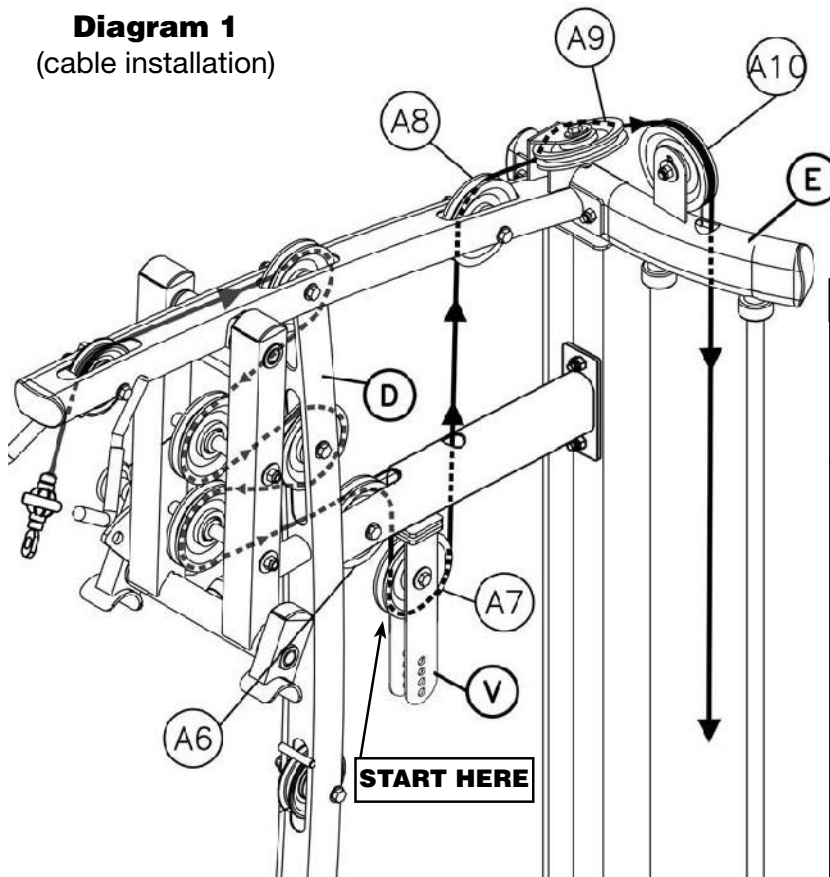

WARNING

Selector Rod Top Bolt (34) must be threaded a minimum of 1/2" into the Selector Rod (31), and Jam Nut (71) tightened securely against spring lock washer (63) to ensure proper connection. Check the Jam Nut (71) once a week to make sure it is tight.

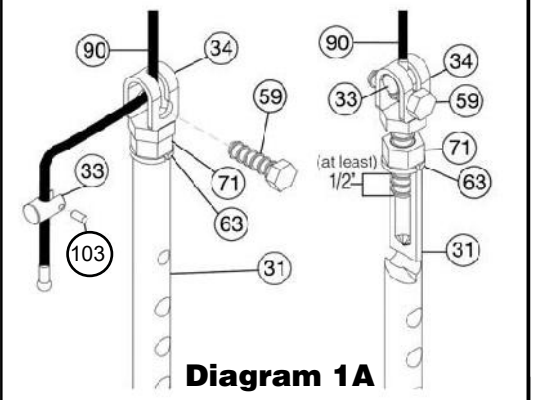
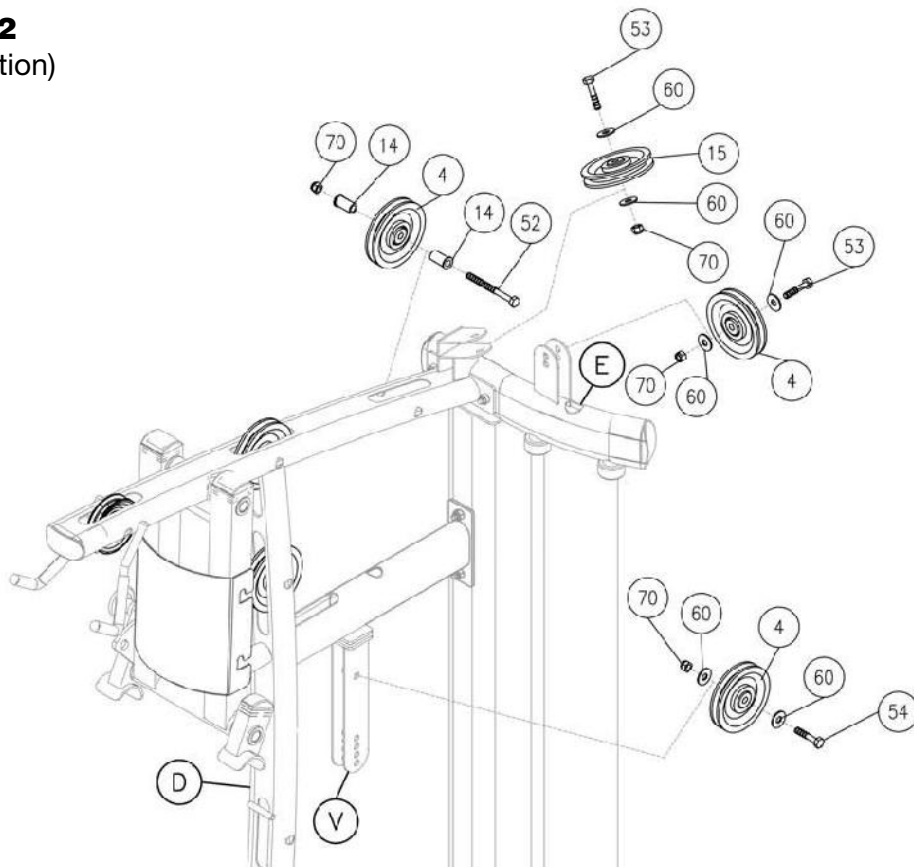

Diagram 2
(pulley installation)



STEP**9**

Be careful to assemble all components in the sequence they are presented.

NOTE:

Finger tighten all hardware first. Wrench tighten at the end of Step 9A. Some components may be pre-assembled. Nylon lock nuts will not fully screw onto bolts, they must be wrench tighten to fully go on.

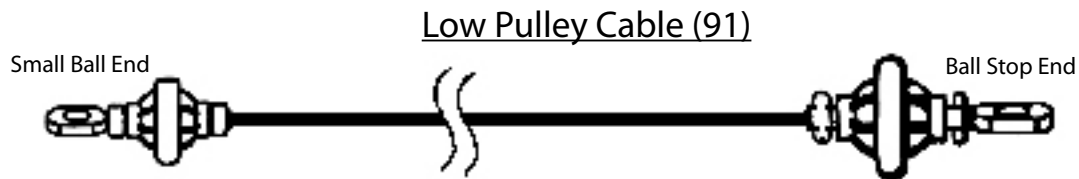

5A. Route Cable (#90) and install 4 Pulleys (#15 & 4) as shown in Step 9 Drawing using:

- 3 - (#52) M10x95mm Hex Head Bolt**
- 1 - (#98) M10x110mm Hex Head Bolt**
- 2 - (#101) M10x30mm Washer**
- 4 - (#70) M10 Nylon Lock Nut**
- 8 - (#14) Pulley Spacer**

Diagram 1
(cable installation)

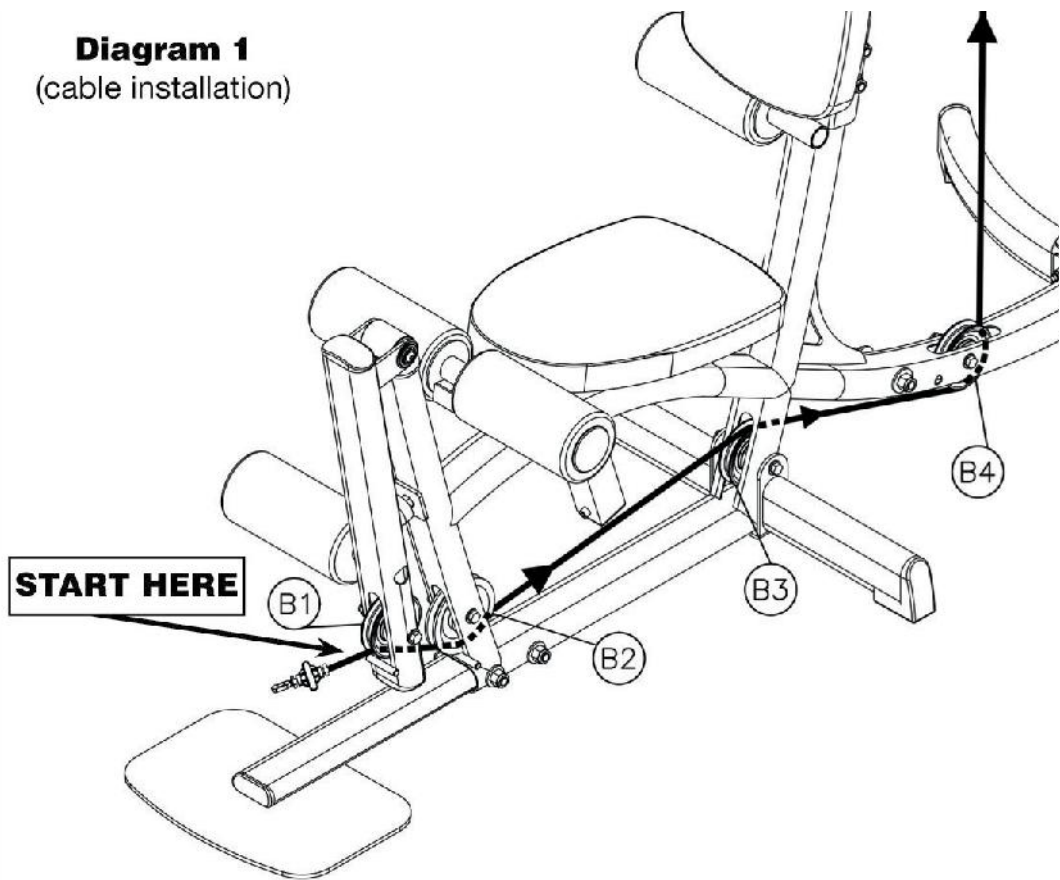
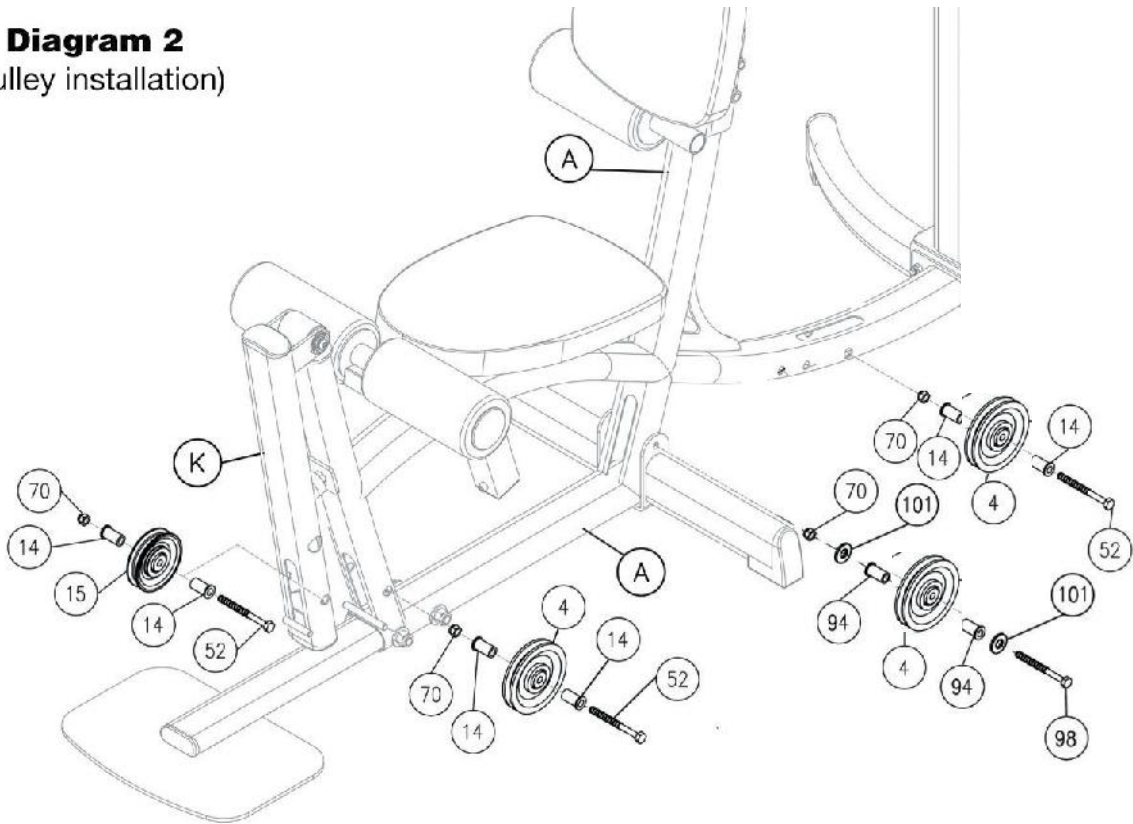

Diagram 2
(pulley installation)



STEP**10**

Be careful to assemble all components in the sequence they are presented.

NOTE:

Finger tighten all hardware first. Wrench tighten at the end of Step 10C. Some components may be pre-assembled. Nylon lock nuts will not fully screw onto bolts, they must be wrench tighten to fully go on.

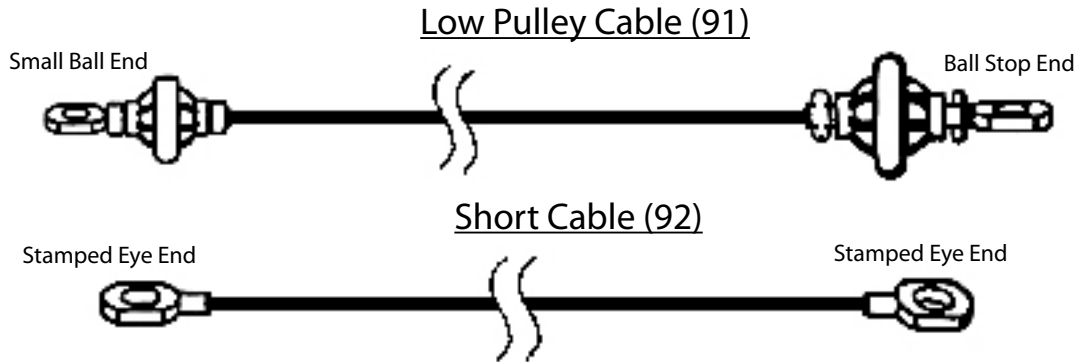

10A. Route Cable (#91) and install 3 Pulleys (#15 & 4) as shown in Diagram 1 & 2 using:

- 1 - (#52) M10x95mm Hex Head Bolt
- 2 - (#54) M10x55mm Hex Head Bolt
- 3 - (#70) M10 Nylon Lock Nut
- 4 - (#60) M10 Washer
- 2 - (#14) Pulley Spacer
- 1 - (V) Upper Floating Pulley Bracket
- 1 - (W) Leg Press Pulley Bracket

10B. Attach Cable (#92) to Lower Main Base Frame (A) in Diagram 1A using:

- 1 - (#52) M10x95mm Hex Head Bolt
- 1 - (#70) M10 Nylon Lock Nut
- 2 - (#60) M10 Washer

10C. Attach Cable (#92) to the hook of Leg Press Pulley Bracket (W) and screw on Acorn Cap Nut (#40).

NOTE: Snap Link (#27) & Steel Chain (#105) to be used for cable (#92) adjustment.

STEP

10

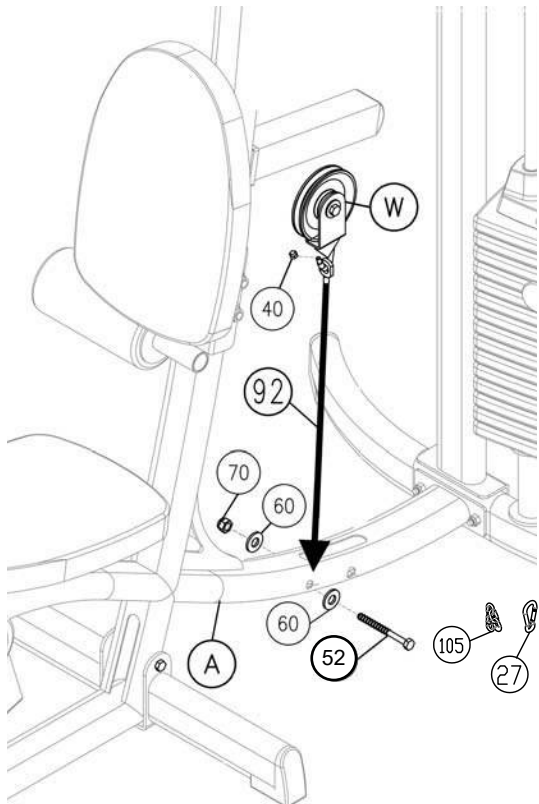

Diagram 1A
(cable installation)

Diagram 1
(cable installation)

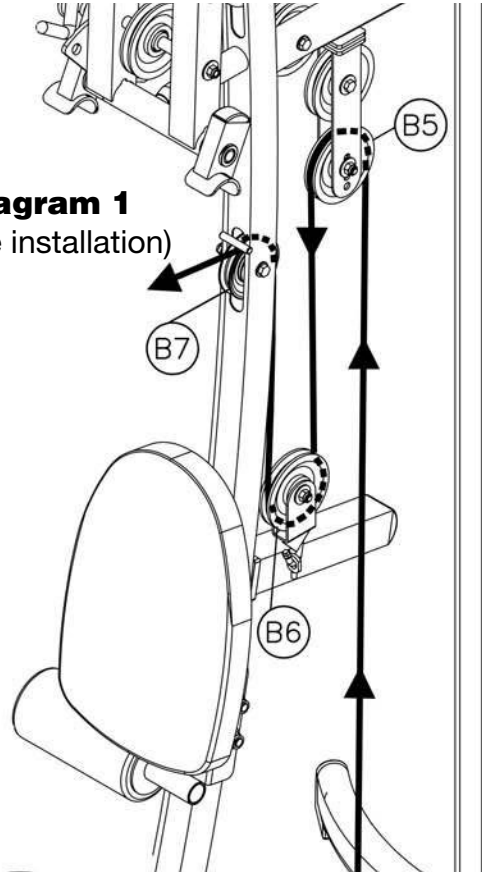
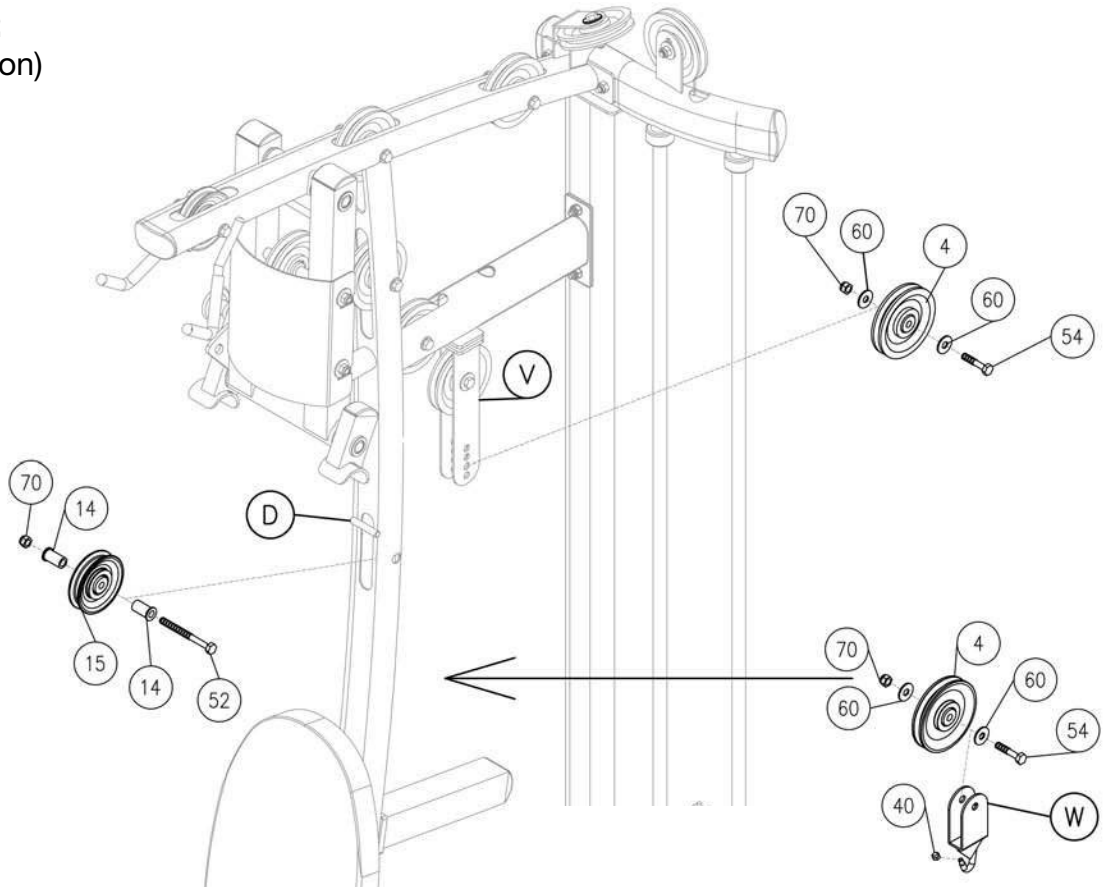
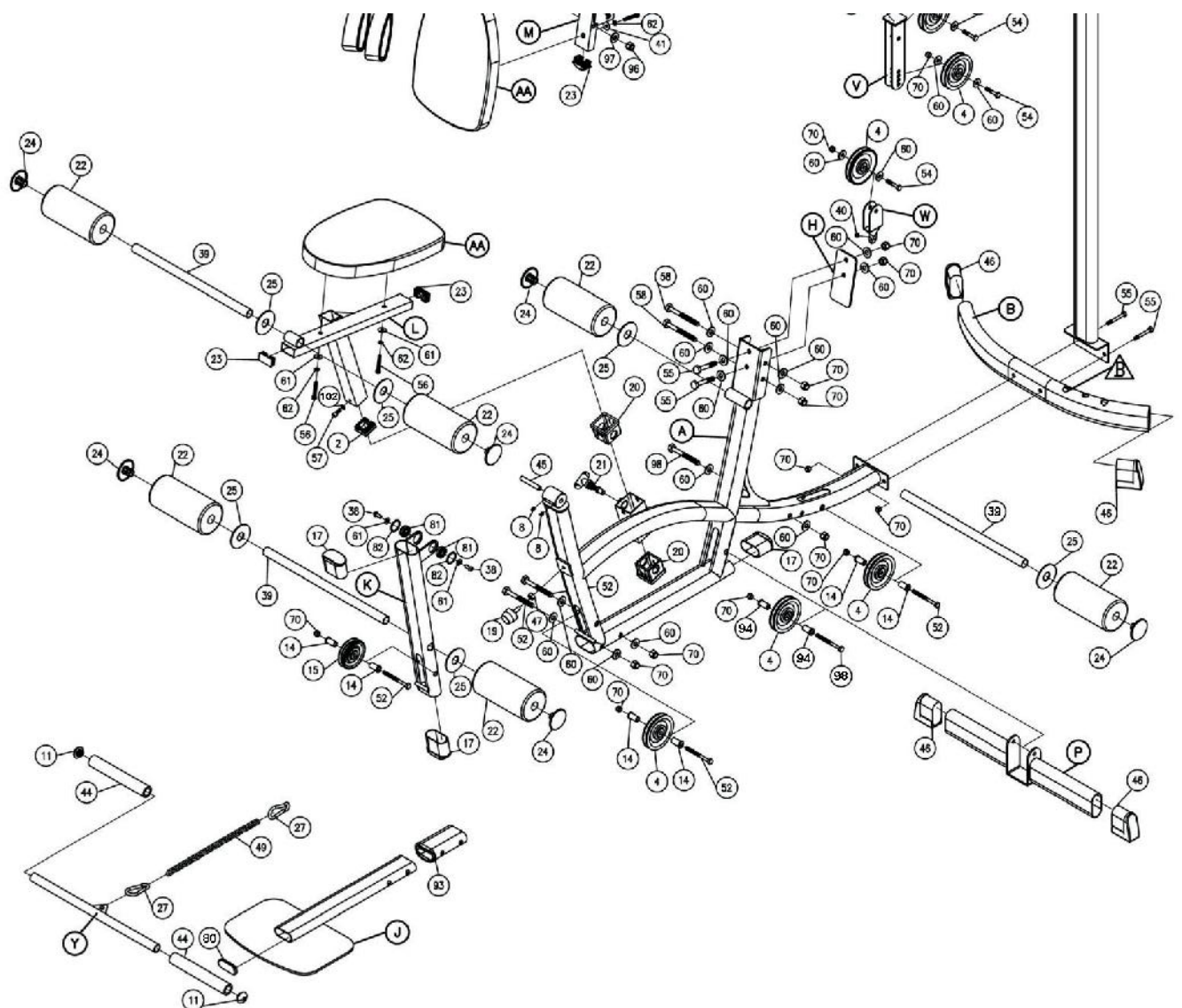

Diagram 2
(pulley installation)



EXPLODED VIEW DIAGRAM 2



BFMG30

PLEASE WRITE YOUR SERIAL NUMBER IN THE BOXES BELOW

S/N # 016187- - - -

1900 S. Des Plaines Ave.
Forest Park, IL 60130
1 (800) 556-3113
Hours: M-F 8:30 - 5:00 CST

